

Model 45A *Interface*

User Guide

Issue 2, November 2011

This User Guide is applicable for serial numbers
M45A-00151 and later

Copyright © 2011 by Studio Technologies, Inc., all rights reserved
www.studio-tech.com

This page intentionally left blank.

Table of Contents

Introduction	5
Installation	10
Configuration	16
Operation	19
Technical Notes.....	24
Specifications.....	27
Appendix A—Interfacing with RTS® Matrix Intercom Systems	28
Appendix B—Interfacing with Riedel® Artist™ Matrix Intercom Systems	29
Appendix C—Interfacing with Clear-Com® Matrix Intercom Systems	30
Appendix D—Model 45A Interface Front-Panel DIP Switch Configuration Chart.....	31

This page intentionally left blank.

Introduction

The Model 45A is designed to interface 2-wire full-duplex party-line (PL) intercom circuits with 4-wire audio circuits associated with matrix intercom systems. Applications for the Model 45A include television sports and live-event broadcasting, theme park and theater installations, corporate AV, and industrial testing environments. The unit provides one full-featured two-channel 2-wire-to-4-wire interface. The interface features hybrid circuitry that includes automatic nulling capability. The analog hybrids, under software control, provide excellent audio quality and high return-loss.

The Model 45A can be powered by an external source of 24 volts DC. The circuitry is designed so that full isolation from the connected party-line circuit is maintained. The connected party-line intercom circuit

can also provide the Model 45A's operating power. For maximum flexibility the unit is capable of supplying 30 volt DC power and AC terminations, thus creating a 2-wire party-line intercom circuit. This allows direct support for devices such as intercom belt packs.

Configuration settings allow the Model 45A's performance to be optimized. Audio level meters provide user confirmation of system performance during setup and operation. Standard audio connectors are used for interfacing audio input, audio output, party-line intercom, and DC power signals. The Model 45A is housed in a compact "1/2-rack" form factor that meets the needs of broadcast "throw-down" applications. Optional front panels allow one or two Model 45A units to be mounted in a single space of a standard 19-inch rack enclosure or one unit can be mounted in a special 10.5-inch rack.



Figure 1. Model 45A with standard "throw-down" front panel

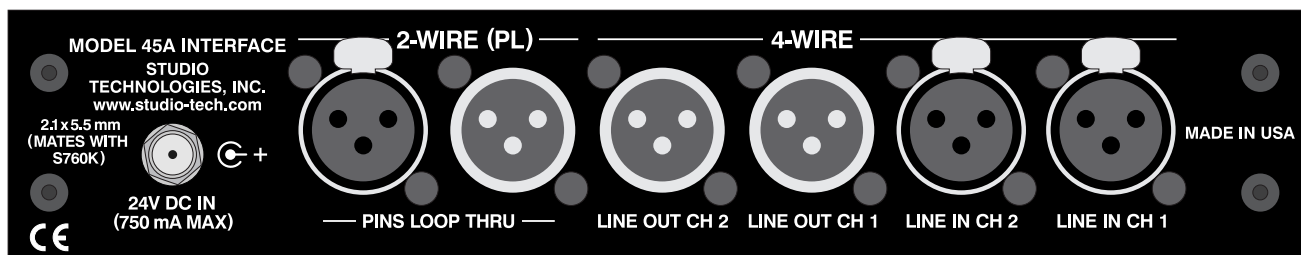

Figure 2. Model 45A back panel

2-Wire Party-Line Interface

The Model 45A's two-channel 2-wire party-line interface is optimized for direct connection with a dual-channel party-line intercom circuit. In addition, single-channel party-line intercom circuits can also be connected. Many broadcast applications use the dual-channel TW-series from RTS®, which includes their popular BP325 belt pack.

The Model 45A's 2-wire interface is configured for a -10 dBu nominal level, exactly matching the level of the TW-series. Other industry-standard single- and dual-channel party-line intercom systems, including those from Clear-Com®, are also directly compatible. While their nominal level is approximately 4 dB lower (-14 dBu) their greater dynamic range tends to compensate for any operational differences.

The Model 45A's 2-wire party-line interface is typically connected to a powered ("wet") unbalanced intercom circuit. Powered party-line circuits have a DC voltage present, typically provided by power supplies from RTS or Clear-Com. This DC power, normally 30-32 volts, provides energy for connected devices such as user stations or belt packs. A configuration setting is used to select how the Model 45A will impact the connected 2-wire circuit. In the default mode the Model 45A's circuitry maintains a high-impedance load and draws no power from the party-line circuit. An alternate mode allows the power required by the Model 45A's circuitry to be supplied by the connected party-line circuit.

A significant capability of the Model 45A's 2-wire interface is its ability to create a fully functioning 2-wire party-line intercom circuit, supplying the required DC power and 200 ohm AC terminations. Referred to as the Model 45A's 2-wire (PL) power

source mode the 30 volt, 300 milliampere maximum output can power devices such as user stations and belt packs. In many applications this will eliminate the need for an external intercom power supply. Besides reducing total system cost, this feature can also lower system weight, reduce required mounting space, and decrease the mains energy requirement.

With the 2-wire interface's ability to supply up to 300 milliamperes of current a typical broadcast application which uses two or three BP325 belt packs can easily be supported. The circuitry's output regulation is such that little change in the output voltage will occur over its entire rated output current. The power source is an "industry-standard" 30 volts DC, helping to ensure that applications requiring long intercom cable runs will function correctly. Also, the design of the power supply circuitry helps to minimize the noise and "hiss" often associated with intercom power supplies. Under software control the DC power supply's output is monitored for over-current and short-circuit conditions. This allows protection shut-down of the output DC, as well as providing an alert by way of a visual indicator.

An auto terminate function ensures that should a party-line circuit not be connected, the Model 45A's interface circuitry will remain stable. This unique feature makes certain that objectionable audio signals, such as oscillations and "squeals," will rarely be sent to the connected 4-wire device.

Analog Hybrids with Auto Nulling

A key reason that the Model 45A achieves excellent audio performance is the design of its 2-wire-to-4-wire hybrid circuits. Each

of the two independent circuits provides low noise and distortion, good frequency response, and high return-loss (“nulling”), even when presented with a wide range of 2-wire party-line conditions. Unlike telephone-line (“POTS”) oriented DSP-based hybrid circuits, the Model 45A’s analog circuitry provides extended frequency response. With a pass band of 100 Hz on the low end and 8 kHz on the high end natural-sounding voice signals can be sent to, and received from, the 2-wire party-line circuit.

A hybrid’s ability to isolate the transmit signal from the receive signal in the 2-wire-to-4-wire interface is critical. The quality of this isolation, technically known as return-loss or trans-hybrid loss, is measured in dB. A high value is important, especially in applications where multiple 2-wire-to-4-wire interfaces are used together. Remote sports broadcast applications are especially sensitive to this requirement. The Model 45A’s sophisticated auto nulling function uses analog circuitry under microprocessor control to achieve significant trans-hybrid loss. This return-loss “null” is achieved by making a set of adjustments to account for the resistive, inductive, and capacitive conditions that are present on the connected 2-wire party-line circuit. The party-line’s conditions are the sum of the impact made by the type and quantity of cable, the connected user devices, and the intercom power source.

Whenever a user presses the Model 45A’s auto null pushbutton switch digital circuitry adjusts the analog hybrids to achieve their maximum return-loss. The nulling process takes approximately 12 seconds for each interface channel. And it’s important to highlight that while the nulling process is automatic, it only takes place upon user

request. The parameters obtained during the nulling process are stored in nonvolatile memory; power interruptions won’t require the auto nulling function to be performed again.

The Model 45A generates a sine-wave audio tone for use during the auto nulling process. The signal’s frequency is software-controlled to maximize the ability of the hybrid circuits to reach a “deep” null. In addition, at the beginning of each auto nulling sequence a short period of 24 kHz tone is sent to the associated channel of the 2-wire party-line interface. This serves as a microphone disable (“mic kill”) signal for user devices such as the RTS BP325. By automatically disabling “open” microphones the auto nulling process can achieve a better result.

4-Wire Interfaces

Associated with the 4-wire portion of the Model 45A’s dual-channel interface are analog line-level inputs and outputs. These are intended to interconnect with a variety of 4-wire devices, including matrix intercom systems, audio-over-fiber transmission systems, and specialized audio equipment. The input and output circuitry is transformer-coupled to minimize the chance of hum, noise, or ground “loop” issues. The nominal input and output levels are +4 dBu, helping to ensure compatibility with professional audio equipment. Some digital matrix intercom systems use other nominal levels but with their configuration flexibility they can be easily adjusted to match the Model 45A. For example, the Riedel Artist® system has a nominal level of +6 dBu so an adjustment of only 2 dB is required. The RTS ADAM™ series of matrix intercom systems has a nominal level of +8 dBu. This

level also applies to their RVON-I/O VoIP products. As such, reducing their nominal input and output levels by 4 dB will ensure optimal compatibility.

The Model 45A contains four 5-segment LED level meters with two displaying the level of the signals being received on the 4-wire inputs and two displaying the level being sent out the 4-wire outputs. During installation and setup the meters are invaluable in helping to confirm that proper operation is taking place. The meters are also useful during normal operation, allowing confirmation of audio signal flow into and out of the Model 45A.

Pro Audio Quality

The Model 45A's audio circuitry was designed in the spirit of professional audio equipment, rather than that found in typical party-line intercom gear. High-performance components are used throughout, providing low distortion, low noise, and high headroom. Using passive and active filters, the frequency response is limited to nominally 100 Hz to 8 kHz. This range was selected to provide excellent performance for human speech, while maximizing the ability of the hybrids to create substantial "nulls." When the Model 45A's internal DC power source is selected to provide 2-wire party-line intercom power enhanced audio performance can also be expected. The quality of the DC supply circuit is very good, with very little noise, hum, or "hiss" being added to the 2-wire connection. In addition, the impedance characteristics of the interface's DC powered ("wet") channel was tailored to be essentially identical to that of the unpowered ("dry") channel. This unique situation allows the automatic nulling circuitry to provide excellent, consistent

results for both the powered and unpowered channel.

Attention to detail is a hallmark of the Model 45A's design. For example, during the brief auto nulling process the interface channel's 4-wire input and output signals are normally muted, preventing unwanted audio from reaching the connected equipment. Associated with the 2-wire party-line interface is circuitry that, under software control, applies 200 ohm terminating impedances to the 2-wire party-line circuit. This, along with other circuitry that monitors DC voltages present on pins 2 and 3 of the 2-wire circuit, ensures that audio instability associated with unterminated circuits will rarely occur.

Special Applications

While the Model 45A is designed to directly integrate into typical applications, it's ready to support the "one-in-a-million" situations too. To accomplish this five DIP switches, accessible on the front panel, allow control over some of the unit's features. For example, one DIP switch changes the way the auto null pushbutton switch operates. Normally pressing the button begins the process of auto nulling both channels. The alternate switch mode allows each auto null sequence to be activated independently. One "tap" of the auto null button will begin the auto null process for channel 1. Two "taps" of the button will begin the auto null process for channel 2. Another DIP switch allows the auto terminate feature to be disabled. While this feature can help maintain audio quality, advanced users might need to disable it. This would allow full control over the Model 45A's two hybrid circuits, enabling them to be used in a completely independent manner.

Simple Installation

The Model 45A uses standard 3-pin XLR-type connectors, allowing convenient 2-wire party-line and 4-wire interconnection in broadcast and general audio environments. For flexibility, access to the 2-wire party-line intercom interface can be made using either a male or female XLR connector on the back panel or a male XLR connector on the front panel.

In many applications the Model 45A will be powered by an external source of 24 volts DC. A compact, lightweight 24 volt DC output power source is supplied with each unit. The power supply's universal mains input capability (100-230 volts, 50/60 Hz) allows operation virtually anywhere in the world. The Model 45A can also be powered by the connected 2-wire party-line intercom circuit.

The four LED meters (previously mentioned) make it simple to confirm operation of the connected 4-wire inputs, 4-wire outputs, and 2-wire party-line circuit. Additional LED status indicators are also provided, offering a clear view of the 2-wire DC power source, auto null functions, and input operating power.

The Model 45A is housed in a rugged, lightweight aluminum enclosure that is designed to be "road tough." The "1/2-rack" unit is ready for portable or stand-alone "thrown-down" applications. Three rack-mount options are also available allowing one or two units to be mounted in one space (1U) of a standard 19-inch rack enclosure or one unit to be mounted in a special 10.5-inch rack.

Design Philosophy

While the "bits and pieces" that make up the Model 45A have been described in

conventional terms, the real strength of the unit rests in the way it integrates and performs in the "real world." Studio Technologies learned from conversations with industry experts that installing and configuring 2-wire-to-4-wire interface equipment has traditionally been a time-consuming, aggravating process, requiring the efforts of an expert to achieve reasonable results. And even under those constraints the resulting audio performance was often mediocre. This "history lesson" made it clear that any new design had to start with a unique set of requirements. This led to an overriding design goal: create a "new breed of cat," fundamentally changing how broadcast 2-wire-to-4-wire interface equipment fits into actual applications.

An important first step was to eliminate the requirement that a senior technician, along with a screwdriver, be present during every installation. (It was universally acknowledged that their time can be better spent elsewhere!) The need to adjust trim potentiometers, fabricate special cabling and connector straps, use nulling ear-pieces, etc. had to be eliminated. For example, in virtually all instances, input and output levels fall within just a few dB of their nominal values and, as such, could be supported with one industry-standard nominal audio level. In addition, it was acknowledged that in this application analog audio circuitry was capable of providing excellent audio performance, but that the required manual nulling process was operationally taxing. By adding digital control to the analog circuitry, automatic nulling could be performed—the best of both worlds!

The next step was to identify resources that would improve the installation process and make operation more reliable. This led to

the use of standard 3-pin XLR-type audio connectors, enabling rapid installation and troubleshooting in any locale. The inclusion of LED level meters allowed continuous monitoring of the input and output signals. Additional status LEDs were also deemed to be valuable. Configuration DIP switches would allow crucial operating modes to be selected.

A subtle but critical requirement was the need for the Model 45A to receive its operating power from either an external 24 volt DC source or the connected 2-wire party-line intercom circuit. It also turned out that in many applications only a small number of user devices, such as belt packs, were typically connected to a 2-wire party-line circuit. So by adding a DC power source to the Model 45A's 2-wire interface the need for an external intercom power supply could often be eliminated.

The final step was to create a physical package that would provide significant resources in a format that allowed simple and reliable integration with other equipment. This was accomplished by specifying a convenient "1/2-rack" form factor which would be excellent for "thrown-down" use. And by creating three "1U" rack-mount options, it would be possible to install one or two Model 45A units in one space of a 19-inch rack or one unit in a special 10.5-inch rack space.

Installation

In this section you will be preparing the Model 45A for use. Since the standard unit is housed in a self-contained enclosure, getting it ready for use in portable applications requires only making a few interconnections. These include 4-wire audio input,

4-wire audio output, and 2-wire party-line intercom connections that use 3-pin XLR-type connectors. In many applications an external source of 24 volts DC will be connected using the supplied power adapter.

For permanent installations one or two Model 45A units can be mounted in one of the optional rack panel adapters. The resulting one-rack-space unit will be mounted in either a 19-inch or a special 10.5-inch equipment rack.

Shipping Carton Contents

The shipping carton contains a Model 45A Interface, a universal input/24 volt DC output power supply, and a user guide. A North-American standard mains power cord will be provided for use with the power supply. If necessary, the dealer or distributor will provide an AC mains cord that is appropriate for your location. If a rack-mount front panel is going to be used as part of the installation it will typically be shipped in a separate carton.

Locating the Model 45A

The location of the Model 45A will dictate the length of the cable runs needed to link the unit with the other required intercom devices. This factor really only relates to the 2-wire party-line intercom circuit. These circuits carry unbalanced audio which can be susceptible to interference and crosstalk issues. And since party-line intercom circuits typically carry DC power a voltage drop due to resistive loss can become an issue. In general, minimizing the length of the 2-wire party-line intercom cables will help to ensure more reliable and consistent intercom system performance. The differential ("balanced") 4-wire circuits are typically not impacted by the

length of their interconnecting cables. A final location criterion is to provide access to the Model 45A's front panel. An optimal location will allow convenient use of the auto null pushbutton and easy observation of the level meters and status LEDs.

Protecting the Enclosure

The Model 45A is shipped as a self-contained unit suitable for portable use. Installed on the bottom of the chassis are screw-on "bump on" protectors. These are useful if the unit is going to be placed on surfaces where scratching of either the Model 45A or the surface could take place. They can be removed, without the use of a tool, when rack-mounting the unit.

Rack Mounting the Model 45A

For permanent or mobile applications it's possible to mount one or two Model 45A units into one space of a 19-inch rack enclosure or one unit in a special 10.5-inch rack. Three rack-mount front panels, purchased separately, are available from Studio Technologies. Refer to Figure 3 for a view of the Model 45A in the "1/2-rack" front panel.

The following provides details on how to install and use the panels. To attach a Model 45A unit to either one of the single-unit rack-mount panels, begin the process by removing the four 4-40 thread hex-head screws that hold the cover onto

the chassis. This requires the use of a 5/64-inch hex wrench. Save the cover, screws, and lock washers for later use. With the cover removed, observe the cable and 3-position socket that are part of the 3-pin male XLR connector assembly that's attached to the standard front panel. Carefully detach the socket from the 3-pin header, located on the main printed circuit board adjacent to the back panel. Remove the 3-pin male XLR connector from the front panel by removing the two Philips-head machine screws. Save the XLR assembly and associated screws for later use.

Use the 5/64-inch wrench to remove the four 4-40 thread hex-head machine screws that hold the standard front panel to the chassis. Save the screws for reuse. Carefully protect and store the standard front panel for possible later use. Using the screws that were just removed, attach the rack-adaptor front panel to the Model 45A's chassis. To prevent damage extreme care is required when aligning the front panel with the LEDs, DIP switch, and auto null pushbutton switch that protrude through both the Model 45A's chassis and front panel. Tighten the four screws only after a careful inspection, ensuring that all parts protrude through the front panel without interference. Reattach the 3-pin male XLR assembly to the front of the rack panel using the two Philips-head screws.



Figure 3. Model 45A shown in optional single-unit "1/2-rack" front panel

Attach the 3-position socket to the 3-pin header located on the main printed circuit board adjacent to the back panel. Ensure that the three pins of the header align with the three openings in the socket. Reattach the top panel, securing it to the chassis with the four screws and lock washers. If required for mounting clearance, remove the “bump on” protectors from the bottom of the chassis.

Mounting the dual-unit rack-mount panel follows the same procedure but applies to two Model 45A units. Store both of the removed standard front panels for possible later use. Note that on the front-panel graphics one unit is designated as A while the other is designated as B. This is provided so that each can be easily identified during installation, troubleshooting, and operation.

Once the desired one or two Model 45A units have been installed in a rack-mount front panel, the assembly can be mounted into the designated equipment rack. One space (“1U” or 1.75 vertical inches) in either a standard 19-inch or a special 10.5-inch equipment rack is required. Secure the unit into the equipment rack using two mounting screws per side.

4-Wire Audio Inputs and Outputs

Two audio line input and two audio line output signals are associated with the 4-wire interface section of the Model 45A. Connections are made using standard 3-pin male and female XLR connectors. Refer to Appendices A, B, and C for details on interconnecting with RTS, Riedel, and Clear-Com matrix intercom systems.

4-Wire Line Inputs

As previously mentioned, the Model 45A’s 4-wire interface allows two analog line-level audio sources to be connected. The source for these signals will typically be ports on a matrix intercom system. It’s also possible that the signals will come from other devices, such as a fiber optic or copper-based audio transmission system. The 4-wire input circuitry is balanced, capacitor coupled, transformer isolated, and has an impedance of 13 k ohms. The line inputs are optimized for signals that have a nominal level of +4 dBu.

Audio sources are connected to the line inputs by way of 3-pin female XLR-type connectors which are located on the Model 45A’s back panel. Refer to Figure 4 for a detailed view.

Prepare the mating connectors (males) so that XLR pin 2 is signal high (+ or hot), pin 3 is low (– or cold), and pin 1 is shield. If connecting a source in this manner results in hum or noise it’s possible that removing the shield connection from pin 1 can eliminate the issue; “floating” pin 1 will remove a ground current path from the Model 45A’s chassis ground point through the shield of a cable. (Pin 1 on each of the two input connectors is internally connected to the Model 45A’s earth/chassis ground point.) Also, if a hum or noise issue does arise be certain to confirm that, unless absolutely necessary, the mating connector’s “shell” isn’t connected to the cables’ shield or pin 1. Termination of this “fourth” pin of a 3-pin XLR connector is often the cause of seemingly inexplicable noise issues.

With an unbalanced source connect XLR pin 2 to signal high (+ or hot) and both pins 1 and 3 to shield. If connecting an

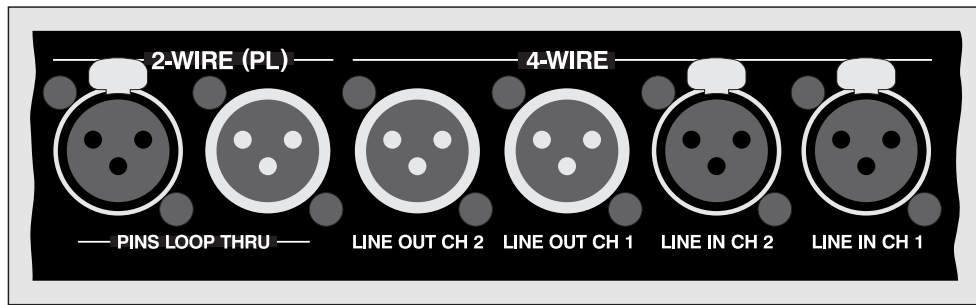

Figure 4. Detail of back panel showing line inputs and outputs

unbalanced source in this manner results in hum or noise, connect XLR pin 2 to high (+ or hot) and pin 3 to shield; leave pin 1 unterminated.

4-Wire Line Outputs

The Model 45A's dual-channel interface provides two analog line-level audio outputs. These outputs are intended to be connected to inputs on the devices associated with the 4-wire audio signals. The outputs are capacitor coupled, transformer balanced with a nominal level of +4 dBu. The 4-wire line outputs are capable of driving inputs that have impedances as low as 600 ohms, however connecting to loads of 2 k ohms or greater is preferred. The line outputs are connected by way of 3-pin male XLR-type connectors which are located on the Model 45A's back panel. Refer to Figure 4 for a detailed view.

The mating connectors (females) should be prepared so that signal high (+ or hot) is expected on XLR pin 2. Signal low (- or cold) should be expected on XLR pin 3. The cables' shields can be connected to XLR pin 1. However, in order to minimize the chance that ground-interaction problems will arise, pin 1 on each of the line output connectors is isolated from all Model 45A circuitry and ground points. "Floating" pin 1 virtually eliminates the

chance that a "ground loop" problem will occur.

2-Wire Party-Line Intercom Connections

The Model 45A's 2-wire party-line intercom interface is designed to connect with a standard single- and dual-channel party-line intercom circuit. This type of circuit typically has positive 28 to 32 volts DC on pin 2 and common on pin 1. The Model 45A's 2-wire party-line interface can also serve as an intercom power source and 200 ohm impedance generator, allowing intercom user devices to be directly connected. The Model 45A's internal 30 volt DC intercom power source is limited to 300 milliamperes of current. This moderate amount of power requires that the type and number of connected user devices be selected appropriately.

For convenience, the 2-wire party-line intercom circuit or user devices can be connected to the back of the Model 45A by way of either a male or female 3-pin XLR-type connector. For flexibility during use, an additional male 3-pin XLR-type connector is located on the front panel. The three connectors are wired in parallel ("multed") and provide access to the identical signals.

Dual-Channel Intercom Systems

If compatibility with RTS TW-series is desired the mating connector (one male or one female) should be wired so that common is on pin 1, DC with channel 1 audio is on pin 2, and channel 2 audio is on pin 3. This wiring scheme applies whether the connected devices are to be powered by an external source or by the Model 45A's internal 2-wire intercom power source.

Single-Channel Intercom Systems

There are two ways of connecting to the Model 45A's 2-wire (PL) intercom connectors when compatibility with Clear-Com single-channel intercom devices is desired. The most direct method is to prepare a male or female 3-pin XLR mating connector so that common is on pin 1, power is on pin 2, and audio is connected on pin 3. With this connection scenario only audio channel 2, associated with pin 3 of the Model 45A's 2-wire party-line intercom interface, will be utilized. Pin 2, the Model 45A's audio channel 1, will only be used for connecting DC power to the connected devices. While the audio resources provided by channel 1 will not be used, the Model 45A can still be used to supply DC power on pin 2. As previously mentioned, the maximum current draw on the 30 volt DC output is 300 milliamperes. Alternatively, an external intercom power supply can support the connected devices.

In some single-channel 2-wire party-line intercom system applications it may be desirable to take full advantage of the two channels associated with the Model 45A's interface. The Model 45A can certainly be used in this fashion, but an adapter will

need to be prepared. The recommended connection method is to create an adapter that "splits" Model 45A's 2-wire (PL) intercom connector into two 3-pin XLR connectors, one for each audio channel. The adapter should use one female and two male connectors. Pin 1 of a female 3-pin XLR intended to mate with the Model 45A will connect to pin 1 of both 3-pin male XLR connectors. Pin 2 of the female XLR will go to pin 3 of the male XLR designated as channel 1. Pin 3 of the female XLR will go to pin 3 of the male XLR designated as channel 2. Refer to Figure 5 for details.

Using this adapter the Model 45A can be directly interconnected with two Clear-Com intercom circuits. However, power for the connected devices must be provided by external power sources. The Model 45A's ability to supply intercom power will not be utilized.

Note: It's critical that the correct configuration settings be made when using the Model 45A's interfaces to support two independent intercom circuits. Specifically, the 2-wire power source configuration DIP switch 2 must be set to its off (down) position. In addition switch 4, auto terminate disable, must be placed in its on (up) position. Refer to the Configuration section of this user guide for details.

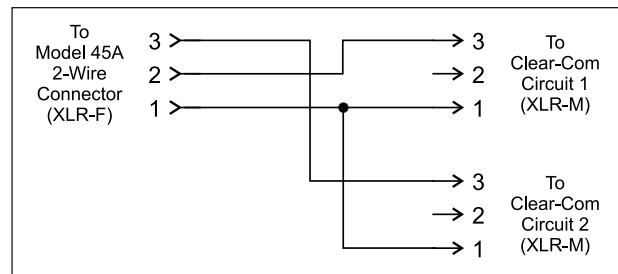

Figure 5. Adapter cable wiring diagram

Model 45A Power Source

The Model 45A requires power for operation of its internal circuitry. This can be provided by an external source of 24 volts DC or by way of the connected 2-wire party-line circuit. As you might expect, if the Model 45A is to serve as the 2-wire party-line power source an external source of 24 volts DC must be connected.

When a 24 volt DC power source is connected it always takes priority. And, depending on how the Model 45A is configured, the Model 45A can automatically switch from using the external 24 volt source to using power from the 2-wire party-line circuit. While this action can occur, it is not designed as a power-fail back-up function. A “seamless” switch over from using the external 24 volt DC input to the 2-wire party-line circuit is not guaranteed. The Model 45A might have a momentary power outage (approximately one second) before again going through the start-up process. Only after this process has completed will operation again commence.

External 24 Volts as the Power Source

As previously discussed, the Model 45A can be powered by a source of 24 volts DC. A “locking” 2.1 x 5.5 mm coaxial power jack is located on the back panel of the unit. The center pin of the jack is the positive (+) connection. While the requirement for the external source is nominally 24 volts, correct operation will take place over a 20 to 28 volt range. The Model 45A requires 750 milliamperes for correct operation. (Approximately 500 milliamperes of this current is used for the 2-wire party-line intercom power source feature.)

Included with each Model 45A is a universal mains input/24 volt DC output power supply. The power supply’s DC output cable has been terminated with a Switchcraft® S760K coaxial power plug. This “locking” type of plug correctly mates with the Model’s 45A’s 24V DC IN jack. The locking feature is important, allowing the external power source to be securely attached to the Model 45A.

A detachable mains cord is used with the power supply’s 3-pin IEC 320 C14-type inlet connector. Included with each Model 45A is a mains cord with a North-American (NEMA 15L) standard plug on one end and an IEC 320 C13-type connector on the other. Units intended for use in other destinations require that the appropriate cord set be obtained from the dealer or distributor.

Using the Connected 2-Wire Party-Line Circuit as the Model 45A’s Power Source

The connected 2-wire party-line intercom circuit can be used to provide the Model 45A’s operating power. The acceptable voltage range is 24 to 32 volts DC, with a required current draw of 175 milliamperes. Note that for the Model 45A to be powered by the connected 2-wire intercom circuit configuration DIP switch 1 must be in its on (up) position. Please refer to the Configuration section of this user guide for additional details.

Before blithely going ahead and powering the Model 45A with a party-line circuit, it’s important to review the possible pitfalls of this arrangement. First of all, compared to most intercom belt packs the Model 45A is a power “hog,” requiring the aforementioned 175 milliamperes of DC current for operation. The other requirement is that

the supplied voltage must be 24 volts or greater as measured directly at the Model 45A's 2-wire (PL) connectors. Whether the connected party-line intercom circuit can provide this much energy will depend on the characteristics of a specific installation. The relevant factors include the capacity of the intercom power supply, the number and type of connected user devices, and the length and type of the interconnecting cables.

The capacity of the intercom power supply must meet or exceed the needs of the connected user devices, including the Model 45A. It's a good idea to perform a calculation of the total maximum current draw prior to attempting to install and use the unit. As a real-time confirmation often these power supplies have status indicators that can provide a direct indication of their ability to supply the connected loads.

In many cases the length and type (gauge) of the interconnecting cable will be the limiting factor as to whether the intercom circuit can provide adequate power for a Model 45A. This is because the intercom circuit's DC voltage will drop in direct relation to the length of the interconnecting cable. And with the Model 45A's relatively large current draw this voltage drop can become appreciable in situations where belt pack operation wouldn't normally be impacted. Performing accurate calculations in this scenario is a bit more difficult but might be required to ensure a reliable installation.

Initial Operation

As soon as a source of power is applied the Model 45A will begin its power-up sequence. As a "boot-up" indication the input power, status, and meter LEDs will

light, one at a time, in a "walk-through" sequence. After the sequence has completed, one of the input power LEDs will light indicating which power source is actively powering the unit. The Model 45A is now fully functional.

Configuration

To support the needs of various applications the Model 45A allows a number of operating parameters to be configured. A 5-position DIP switch assembly, located on the front panel, is used to establish the desired configuration. Refer to Figure 6 for a view of the DIP switch and to Appendix D for a list of the configuration choices.

Using the Connected 2-Wire Party-Line Circuit as the Model 45A's Power Source

Configuration DIP switch 1 is used to select whether or not the connected 2-wire intercom circuit can be used to provide power for the Model 45A. When the switch is in its off (down) position the intercom circuit cannot be used to power the Model 45A. This ensures that no current will be drawn from the intercom circuit, something that can be important if the circuit is limited in available current, or if the length of the interconnecting cable is excessive. When switch 1 is in its on (up) position the 2-wire party-line circuit can serve as the power source for the Model 45A.

It's important to remember that if an external source of 24 volts DC is connected it will always be used as the Model 45A's power source. Even if switch 1 is in its on (up) position, power will be drawn from the connected intercom circuit only

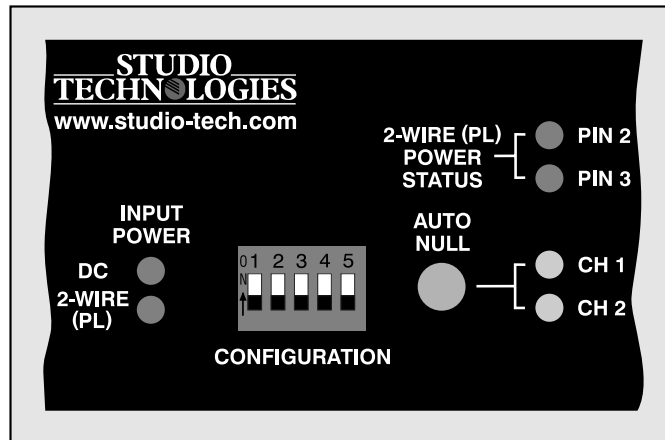

Figure 6. Details of front panel showing the five configuration DIP switches

if the external source of 24 volts DC is not present. With that in mind, it's highly recommended that unless the application has been carefully designed, any time an external source of 24 volts is going to be connected switch 1 should be placed in its off (down) position. This ensures that a failure of the connected 24 volt DC source won't cause the Model 45A to automatically revert to pulling power from the intercom circuit.

Some additional details might be helpful. Be certain to allow only the connected intercom circuit to supply power (switch 1 on) if it's fully able to do so. Trying to draw current from a circuit that's not capable of supplying the needs of the Model 45A will typically result in greatly degraded intercom audio quality. This is because the Model 45A's power supply circuit will always attempt to draw the current it requires. If it's able to do so a constant high-impedance load will be applied to the circuit and everything will perform correctly. But if the party-line intercom circuit isn't capable of providing the required voltage and current the Model 45A's circuitry will become unstable and negatively impact the intercom circuit's audio quality. Howls,

squeaks, and squeals are the expected failure mode! No damage will be done but intercom performance will be greatly compromised.

In conclusion, the Model 45A can function very well using the intercom circuit as its power source. But this requires that the circuit can meet the voltage and current requirements.

Model 45A Provides 2-Wire Party-Line Power Source

Configuration DIP switch 2 is used to select whether or not the Model 45A will serve as an intercom power source, providing DC power and 200 ohm terminations to the intercom interface. When switch 2 is in its off (down) position the Model 45A will not serve as an intercom power source. This setting is appropriate when an external intercom power supply is providing power and terminations to the connected 2-wire intercom user devices. When switch 2 is in its on (up) position the Model 45A can provide the intercom power source, with the requirement that an external source of 24 volts DC is connected to the Model 45A.

Auto Null Button Operation

A pushbutton switch, located on the Model 45A's front panel, is used to activate the auto nulling functions. A configuration parameter allows selection of the button's operation. The choices are dual auto null mode and independent auto null mode. When dual auto null mode is selected a single "tap" (press and release) on the pushbutton switch initiates a routine that begins with channel 1's auto null sequence, followed immediately by channel 2's auto null sequence.

The independent auto null mode allows the auto null function to be initiated for each channel as desired. A single "tap" will start the auto null routine for channel 1; two "taps" will start the routine for channel 2.

When configuration DIP switch 3 is in its off (down) position the dual auto null mode is selected. This is provided specifically for cases where the Model 45A's 2-wire party-line interface will be used with dual-channel intercom user devices. As an example: the RTS TW-series provides two independent audio channels, as well as power, over a single 3-conductor cable. In a case such as this it's useful for both of the hybrid circuits associated with an interface to be auto nulled at approximately the same time. The dual auto null mode allows a single "tap" of the button to initiate nulling of both hybrid circuits.

When configuration DIP switch 3 is in its on (up) position the independent auto null mode is selected. This is appropriate for applications in which the two audio paths associated with the Model 45A's intercom interface are used with independent party-line intercom circuits. This situation might arise when two Clear-Com

single-channel intercom circuits are connected to the Model 45A. The hybrid circuit associated with each channel can be auto nulled as desired. Another example would be in an RTS TW-series application that uses source assignment panels. The "SAP" panels would be used to route multiple intercom channels to various sets of user devices as desired. In this case, the two channels associated with the Model 45A's interface will often end up not routed to the same user device. Independent auto nulling is certainly desired.

Auto Terminate Disable

The auto terminate function is designed to ensure that each 2-wire-to-4-wire interface circuit remains stable under most operating conditions. It can only be active when the Model 45A is not serving as the intercom power source. The auto terminate function applies 200 ohm impedances to both pins 2 and 3 of the 2-wire party-line interface when no source of DC power is detected on either of those pins. This function is directly compatible with RTS TW-series intercom applications in which the three conductors of a cable support both DC power and two channels of audio. It's also compatible in situations where all three conductors of a Clear-Com single-channel intercom circuit are connected to the Model 45A. In this latter case only one of the Model 45A's audio channels will be used.

There may be situations where it's necessary for the two channels associated with the Model 45A's interface to be used with separate 2-wire party-line circuits. An example of this might be where two "loops" of single-channel belt packs, such as units from Clear-Com, need to be connected. In this case the intercom circuit's DC power

will not be connected to the Model 45A, but only to the user devices. In this scenario, a DC voltage won't be present on pin 2 or pin 3. Another example of this might be where adapter boxes with DC blocking are used to interconnect intercom circuits with the Model 45A. In both these cases a DC voltage won't be present on either pin 2 or 3 and the Model 45A will automatically apply 200 ohm terminations. These terminations would be in error, resulting in incorrect audio levels due to a double-termination condition.

To prevent this problem the auto terminate function can be disabled. When configuration DIP switch 4 is in its off (down) position the auto terminate function is active. When switch 4 is in its on (up) position the auto terminate function associated with each interface is disabled.

The auto terminate disable function should be used only when absolutely necessary; it's possible that a significant downside could be experienced. With auto terminate disabled it's important that properly terminated 2-wire party-line intercom circuits be connected to pins 2 or 3 of the Model 45A's 2-wire (PL) interface. If they are not connected, it's likely that audio oscillations, noise, and distortion will be generated in the Model 45A's 2-wire-to-4-wire converter circuitry. These audio artifacts will not cause any damage but will be sent out of the 4-wire line outputs. Users of the 4-wire equipment may be less than pleased with what they hear!

4-Wire Mute during Auto Null

As part of the auto nulling process audio tones are generated and sent out the 2-wire intercom interfaces. These tones, depending on the nulled state of the

hybrid circuits, will also appear on the outputs of the 4-wire interface circuits. To prevent these unwanted tones from being sent to the inputs of the connected 4-wire devices by default the 4-wire outputs mute when the auto nulling process is active.

There may be cases, primarily at the factory, where it's desirable to have the nulling tones appear on the 4-wire outputs. Configuration DIP switch 5 allows the muting of the 4-wire outputs to be disabled.

When switch 5 is in its off (down) position the Model 45A operates in its standard fashion. When switch 5 is in its on (up) position the 4-wire outputs will not mute during the auto nulling process. As expected, when the Model 45A is deployed in the field switch 5 should remain in its off (down) position. However, no damage to the Model 45A or connected equipment will occur when muting during auto null is disabled.

Operation

Upon power-up the Model 45A will always go through a short initialization sequence before normal operation will begin. The LEDs will light sequentially and, upon completion, the applicable input power LED will light. The null settings for the two hybrid circuits are recalled and used, having been previously stored in nonvolatile memory.

Significant user intervention is typically not required during normal Model 45A operation. The unit is designed for continuous operation with no routine adjustment or maintenance necessary. Assuming that the desired configuration has been selected using the DIP switches, only occasional activating the auto null function should

be necessary. The latter may be warranted should connected user devices or wiring associated with the 2-wire party-line intercom circuit be changed.

External 24 Volt DC Power Source

In many applications an external source of 24 volts DC will be connected to the Model 45A. Typically this will be in the form of the external power supply provided with the unit by Studio Technologies. The 24VDC input power status LED will light whenever the external source is providing power for the unit's circuitry. In this scenario the Model 45A can be configured as to whether or not it acts as a power source for the 2-wire party-line interface circuit.

When the Model 45A is Not Serving as the 2-Wire Intercom Power Source

When an external source of 24 volts DC is connected and the Model 45A is configured to not provide 2-wire party-line intercom power (configuration DIP switch 2 set to off), the unit will not provide power to, nor take power from, pin 2 of the 2-wire (PL) connectors. The 4-wire inputs and outputs, as well as the internal power supply, are fully isolated from the 2-wire intercom circuit. In this situation the Model 45A's only function is to route, by way of the hybrids, the 2-wire interface's audio signals to and from the 4-wire outputs and inputs. In this mode of operation the Model 45A acts as a typical user station on the connected intercom circuit.

As a connection confirmation, hardware and software in the Model 45A monitors pins 2 and 3 of the 2-wire (PL) intercom connectors for the presence of DC voltage. A level greater than approximately 18 volts

DC on pin 2 will cause the status LED labeled PIN 2 to light. A level greater than 18 volts DC on pin 3 will cause the status LED labeled PIN 3 to light.

The author is aware that user intercom devices almost always draw power from pin 2 rather than pin 3. However, in many broadcast applications power is provided on all intercom paths so that flexible channel assignments can be made. In the external 2-wire power mode the Model 45A is simply an observer; whether intercom power is present on pin 2, pin 3, or both pins 2 and 3 is not significant.

In order that the Model 45A's 2-wire-to-4-wire interface circuits remain stable and don't generate audio artifacts an auto terminate feature is implemented. This maintains a 200 ohm termination on both pins 2 and 3 as long as neither of the 2-wire power status LEDs is lit. To clarify, if either or both the LEDs are lit then both terminations are removed. It was felt that this method would provide a fairly accurate indication that an active intercom circuit is connected. In this case the 200 ohm termination is expected to be provided elsewhere, typically as part of the external power supply, and the Model 45A's termination is "lifted."

When the Model 45A is Serving as the 2-Wire Intercom Power Source

When configuration DIP switch 2 is set so that the Model 45A provides 2-wire (PL) power its interface supplies 30 volts DC on pin 2 of the 2-wire (PL) intercom connectors. A maximum current draw of 300 milliamperes is available. This current is sufficient to power various intercom user devices such as small user stations and belt packs. A common broadcast

application would be to use RTS BP325 belt packs. Select the connected devices so that their total current doesn't exceed 300 milliamperes. That's not always the easiest figure to calculate but a web search will generally find specifications for all commonly used devices. For example, a search finds that the original version of the BP325 consumes a maximum of 85 milliamperes of current. According to this figure up to three of these units can be connected to each Model 45A Interface. Newer versions of the BP325 use surface mount component technology and have a lower maximum current draw of 65 milliamperes. Four of these "modern" BP325 units can easily be supported.

The Model 45A's intercom power supply circuit operates under software control. This allows detection of fault conditions and protection of both the Model 45A's circuitry and connected intercom user devices. Upon initial Model 45A 2-wire intercom power up no monitoring of the intercom power output takes place for a period of five seconds. This allows the Model 45A's circuitry and the connected intercom user devices to stabilize. The LED associated with pin 2 will light to indicate that the output is active. After this initial 5-second period monitoring becomes active. A fault condition is detected if the power on pin 2 falls below 24 volts for a continuous 1-second interval. The hardware and software responds to this condition by turning off the power source to pin 2 and flashing the pin 2 LED as a warning. After a 5-second "cool-down" interval the output returns to the same condition as upon initial power up. Power is again applied to pin 2, the pin 2 status LED will light, and monitoring won't begin for another five seconds.

A full short-circuit condition applied to the Model 45A's 2-wire connectors will result in a continuous cycle of six seconds on (five seconds for start up and one second for detection) and five seconds off.

As a diagnostic aid the 2-wire (PL) power status LED associated with pin 3 always remains active, even when the Model 45A is supplying power to the 2-wire party-line intercom circuit. Whenever DC in excess of approximately 18 volts is present on pin 3 the LED will light. This condition will typically not exist but could prove useful in special circumstances.

2-Wire Circuit Serves as the Unit's Power Source

If no external source of 24 volts DC is connected and configuration DIP switch 1 is in its on (up) position, the connected 2-wire party-line circuit can provide power for the Model 45A. If this condition is active the 2-wire (PL) input power LED will light. The 2-wire (PL) power status LED will also be lit, indicating that power in excess of 18 volts is detected on pin 2. The pin 3 LED will also light if the same condition is present on pin 3.

Level Meters

The Model 45A contains four 5-segment LED level meters. These meters are provided as a support aid during installation, configuration, operation, and troubleshooting. The meters represent the strength of the signals coming in from, and going out to, the 4-wire connections. The meters are organized in two groups each representing one input and one output. They are calibrated to reflect the level in dB relative to +4 dBu. This is similar to the way in which now-legacy VU meters functioned. As an

example let's take the situation where an output ("to 4-wire") LED labeled 0 dB is lit. (For this example, the level on the 2-wire party-line circuit is just large enough to light the 0 LED.) This indicates that a signal with an approximate level of +4 dBu is present on the associated 4-wire output connector.

Each level meter contains four green LEDs and one yellow LED. The four green LEDs indicate signal levels at or below +4 dBu. The top LED is yellow and indicates a signal that is 6 dB or greater than the +4 dBu nominal level. An audio signal that causes the yellow LED to light doesn't necessarily indicate an excessive level condition, but it does provide a warning that at some stage reducing the signal level may be prudent. Typical operation with normal signal levels should find the meters lighting near their 0 dB point. Signal peaks may cause the yellow LEDs to flash. But a yellow LED that lights fully during normal operation will typically indicate a signal level or configuration problem.

If the meters consistently display lower or higher levels than their 0 dB points it's possible that a configuration issue exists. This would typically be related to incorrect settings on the equipment connected to the 4-wire inputs and outputs. It's possible that although a connected 4-wire device's nominal level matches the Model 45A's level setting its actual nominal level may be significantly different. With a digital matrix intercom system this problem could be due to an incorrect configuration having been made to a specific channel or port. For example, the RTS ADAM system has a published nominal level of +8 dBu, but using its configuration software it's possible to set panels or ports to a level

different than nominal. The best solution in this case is to adjust the associated port on the intercom system so that its levels comply with +4 dBu. This should, at least in theory, lead to the best system performance, including correct interfacing with the Model 45A. But often it's impossible to "clean up" the levels of an existing system.

The "to" 4-wire meters display the level of signals that come from the 2-wire party-line circuit and go out the 4-wire interfaces. An issue may arise if the signals coming from the connected party-line user devices aren't at a sufficient level so that a normal meter display can be reached. This could be the result of an incorrectly configured 2-wire nominal audio level.

It's also possible that an error is present on the 2-wire party-line circuit. Signal levels associated with 2-wire party-line circuits depend on a single termination being present. This termination, typically 200 ohms, is almost always made at the power supply source. But it's possible that another device, such as a second active power supply on the same circuit, will cause a "double-termination" condition. This leads to a nominal 100 ohm line impedance which will result in a level drop of at least 6 dB. Removing the unwanted termination is really the only valid means of correcting the problem.

Auto Null

The Model 45A contains circuitry to automatically null the two 2-wire-to-4-wire interfaces. Normally this process is performed at the time of initial Model 45A configuration but there's no reason why "auto nulling" can't be initiated anytime one desires. The only time that auto null must be performed is if conditions have

changed vis-à-vis the intercom user devices and wiring connected to a Model 45A's 2-wire (PL) connectors. Even a slight change to an intercom circuit, such as adding or removing a section of cable, is sufficient to require that the auto null process be performed.

A pushbutton switch is provided to activate the auto null process. Refer to Figure 7 for a detailed view. To initiate auto null requires simply pressing and releasing (“tapping”) the button. The process begins by nulling channel 1 of the interface and, when completed, moves on to channel 2. Two LEDs provide a visual indication of the auto null process, flashing when the auto null process for its respective channel is active.

An auto null sequence begins with the muting of the 4-wire input and output signal paths associated with the channel being nulled. This is followed by a short period of 24 kHz signal that is sent out the 2-wire party-line intercom interface channel. This will turn off microphones on those connected user devices that are compatible with the RTS TW-series “mic kill” protocol. The actual auto nulling process is performed next. A series of tones will be sent out the 2-wire interface. Other Model 45A circuitry,

under software control, will rapidly perform adjustments to achieve the best null possible. After the adjustments have been made the results are stored in nonvolatile memory. Once the process is complete the 4-wire input and output paths are again activated.

Configuration DIP switch 3 allows an independent auto null button mode to be selected. If switch 3 is in its on (up) position, the front-panel pushbutton will function in quite a different manner. In the independent mode, a single “tap” to a switch will cause channel 1 to auto null. Two “taps” will cause channel 2 to auto null. By observing the operation of the two auto null status LEDs it will become readily apparent which of the button modes has been selected.

If possible, prior to performing an auto null it's polite to warn all personnel who are actively using the connected intercom devices. The tones sent to the 2-wire intercom circuit during the nulling process are not excessively loud or obnoxious, but most users might want to remove their headsets during the process. In addition to warning users, it might be a good time to ask them to mute any active microphones. While the automatic “mic kill” signal will apply to many user devices it may not apply to all. Muting microphones is significant as obtaining a “deep” null requires that no extraneous signals be present on the intercom circuit.

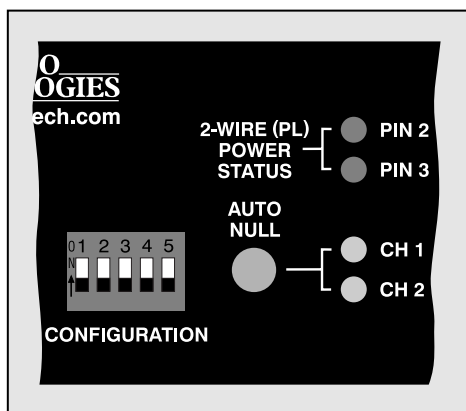

Figure 7. Detail of front panel showing auto null section

Auto Terminate Disable

As previously discussed in this user guide, the auto terminate function can come into play when the 2-wire party-line interface is configured to not supply power. Using a combination of hardware and software,

pins 2 and 3 of the 2-wire (PL) intercom connector are monitored for the presence of DC voltage. If a level of greater than approximately 18 volts DC is not detected on either pin, 200 ohm terminating networks are applied to those same pins. This ensures that the Model 45A's hybrid circuitry remains stable, preventing objectionable audio signals from being sent to the 4-wire output connectors. One caveat does apply: there may be a few seconds of severe noise whenever an interface moves from a DC present condition to a DC not present condition. But other than that period, the audio paths will remain "clean."

As a visual aid, LEDs on the front panel will display the DC power status of pins 2 and 3. But when auto terminate disable mode is active (configuration DIP switch 4 set to on) the LEDs will no longer indicate the intercom circuit's termination status.

For special applications the auto terminate function can be disabled. This will primarily come into play when "splitting" the Model 45A's resources into two separate single-channel interfaces. Moving configuration DIP switch 4 to its on (up) position disables the auto terminate function. To someone observing only the Model 45A's front panel this change would not be readily apparent. The front-panel LEDs will continue to display the DC power status of pins 2 and 3. But whether or not either or both LEDs are lit, the Model 45A will never apply 200 ohm terminations to pins 2 or 3. For the hybrid circuits to remain stable termination impedances must be provided by the connected circuits. If these are not present one might find the hybrid circuits generating very unpleasant audible noise. This condition, caused by the 2-wire output circuitry being in an "unloaded" state, will not damage

the Model 45A's circuitry. However, without the auto terminate function a disconnected cable or other real-world wiring problem could present users with a rude surprise!

In conclusion, it's important that technical personnel working with the Model 45A be informed when the auto termination function has been disabled. They will then be aware of the potential noise issues and be ready to make corrections should a problem arise.

4-Wire Mute During Auto Null

Normally, the 4-wire outputs are muted whenever the auto null process is taking place. This ensures that the test tones generated as part of the nulling process will not be heard by users of the signals associated with the 4-wire outputs. For special applications configuration DIP switch 5 allows the automatic muting mode to be disabled. This mode is provided primarily for use by factory personnel or during demonstration use. During normal operation switch 5 should remain in its off (down) position. When switch 5 is in its on (up) position 4-wire muting during auto null will not take place. While not appropriate during actual Model 45A use, it is interesting to "hear" the nulling process take place. But unless there's a really good reason, configuration DIP switch 5 should always remain in its off (down) position.

Technical Notes

Software Version Display

A special Model 45A power-up sequence allows the unit's software version number to be displayed. This is useful when working with factory personnel on application

support and troubleshooting situations. The five “from” 4-wire LEDs are used to display the major release number with a range of 1 through 5. The five LEDs associated with “to” 4-wire channel 1 are used to display the release sub-number which ranges from 1 through 5. Refer to Figure 8 for a detailed view of the LEDs and the corresponding software version numbering scheme. The Model 45A’s initial software release is version 1.1 which is represented by the bottom LED of each column being lit.

To display the Model 45A’s software version is very simple. From the powered-down state, press and hold the auto null button. While continuing to press the auto null button, apply power either by connecting an external 24 volt DC power source or a powered intercom circuit. The normal power-up sequence will not occur but instead one LED in the status column will be lit and one LED in the column associated with “from” 4-wire channel 1 will also be lit. As previously described, these two LEDs represent the

unit’s current software version. After the software version number has been “read” the auto null button can be released. At this time the unit will begin its normal power-up sequence.

Note that while it’s easy to determine which software version is loaded into the Model 45A a trip back to the factory is required to update it. The 8-bit micro-controller that provides the unit’s logic “horsepower” also includes internal FLASH memory. This nonvolatile memory is used to store the operating software (“firmware”). Re-programming this memory requires using a specialized programming unit. While not outrageous in price, it still costs in the range of US\$500. The programmer uses a ribbon cable and socket to interface with a 6-pin “header” on the Model 45A’s printed circuit board. And, as you would guess, once connected reprogramming takes only a matter of seconds. But unfortunately the programmer

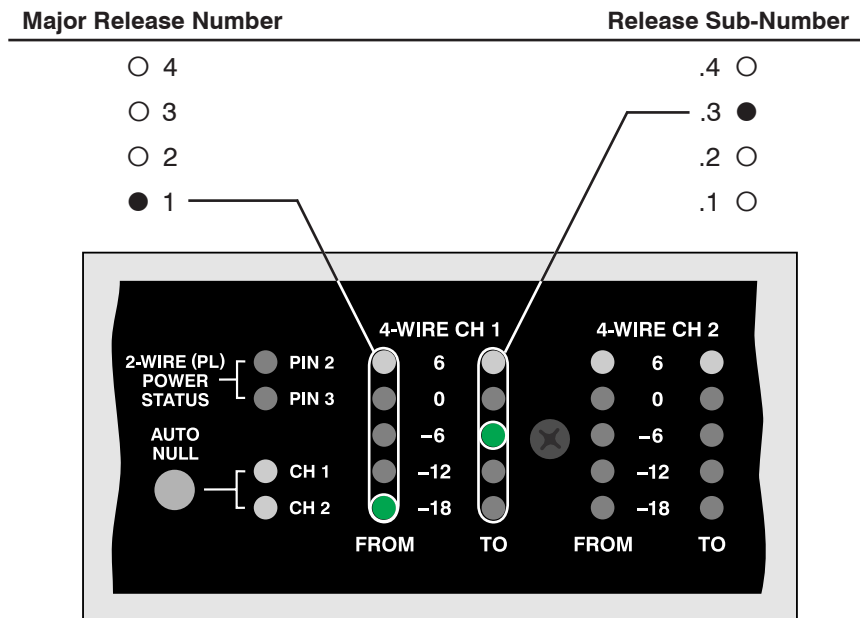

Figure 8. Detail of front panel showing the status LEDs that display the software version. In this example, the software version is 1.3.

is not something that would be found in a typical “field shop” or repair facility.

Two Units can be a TW-12B Replacement

Two Model 45A units with their 4-wire interface connectors linked in a crossover fashion can act as a universal 2-wire-to-2-wire “bridge.” This should, in theory, create an updated and improved version of the venerable Clear-Com TW-12B unit. In this arrangement two independent 2-wire party-line intercom systems can function as one while still maintaining full electrical isolation.

The connection scheme is very simple, using just four male-female 3-pin XLR patch cords. The 4-wire outputs of the first Model 45A would be connected to the 4-wire inputs on the second Model 45A; the 4-wire outputs on the second Model 45A would connect to the 4-wire inputs on the first Model 45A. A 2-wire party-line intercom circuit would connect to each Model 45A unit. Power can be provided by the connected intercom circuits or by way of an external source of 24 volts DC. The final step to achieve correct performance is for the auto null function on each Model 45A to be activated. Refer to Figure 9 for details.

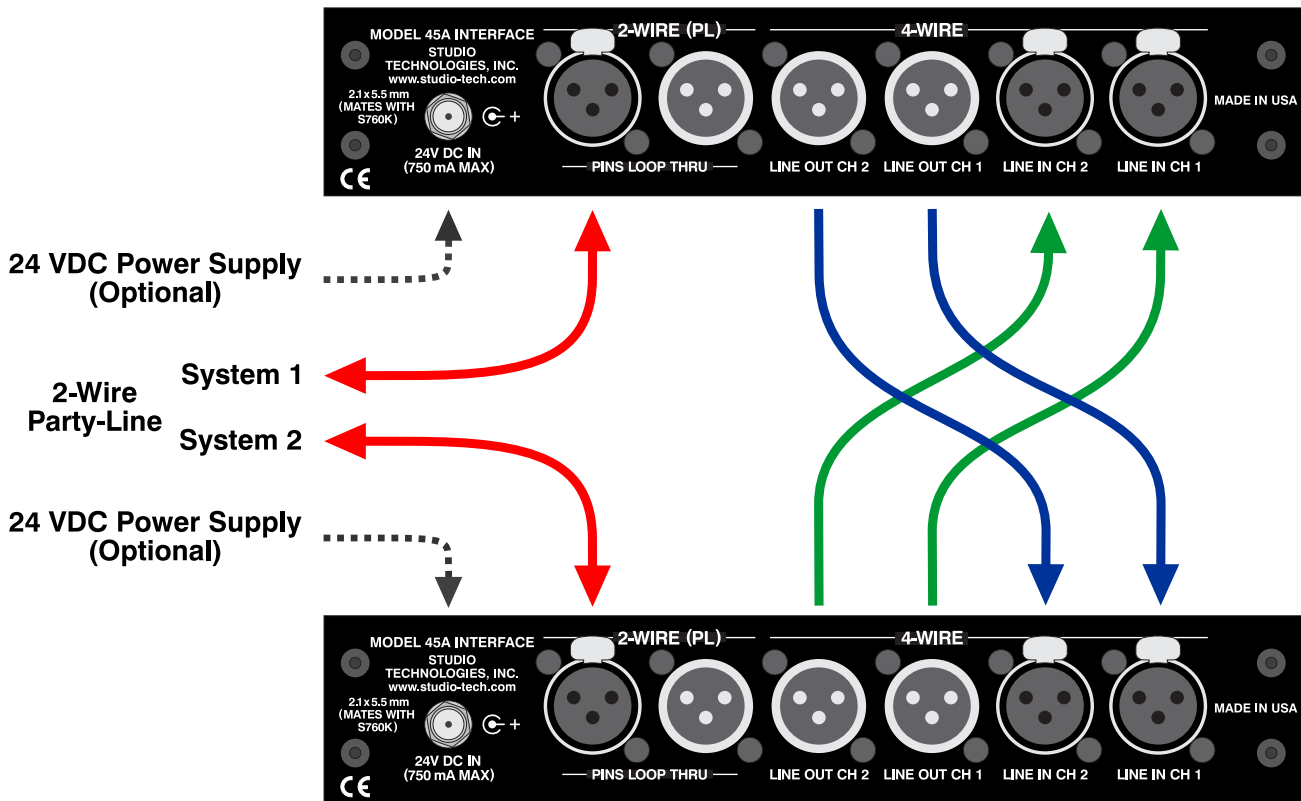

Figure 9. Two Model 45A units connected as a universal 2-wire-to-2-wire bridge

Specifications

General Audio:

Frequency Response: ± 2.5 dB 100 Hz to 8 kHz

Distortion (THD+N): $< 0.2\%$, measured at 1 kHz, 4-wire input to 2-wire interface pin 2

Signal-to-Noise Ratio: > 55 dB, measured at 1 kHz, 4-wire input to 2-wire interface pin 2

2-Wire Party-Line (PL) Intercom Interface:

Type: two-channel party-line, unbalanced (pin 1 common; pin 2 DC with channel 1 audio; pin 3 channel 2 audio)

Compatibility: single- and dual-channel intercom systems such as from RTS® and Clear-Com®

Impedance – Normal: > 10 k ohms

Impedance – 2-Wire (PL) Power Source Mode: 200 ohms

Nominal Level: -10 dBu

“Mic Kill” Signal: square wave, 24 kHz, $\pm 1\%$

2-Wire Power Source: 30 volts DC nominal, 300 milliamperes maximum

Hybrids: 2

Topology: 3-section analog circuitry compensates for resistive, inductive, and capacitive 2-wire party-line loads

Nulling Method: automatic upon user initiation, processor implements digital control of analog circuitry; null settings stored in nonvolatile memory

Nulling Line Impedance Range: 120 to 350 ohms

Nulling Cable Length Range: 0 to 3500 feet, typical

Trans-Hybrid Loss: > 40 dB, typical at 800 Hz

4-Wire Inputs: 2

Type: transformer-coupled, capacitor isolated

Impedance: 13 k ohms

Nominal Level: $+4$ dBu

Maximum Level: $+22$ dBu

4-Wire Outputs: 2

Type: transformer-coupled, capacitor isolated

Impedance: 50 ohms nominal

Nominal Level: $+4$ dBu

Maximum Level: $+20$ dBu into 2 k ohms

Meters: 4

Function: displays level of 4-wire inputs and outputs

Type: 5-segment LED, modified VU ballistics

Connectors:

4-Wire Line Inputs: 3-pin female XLR-type

4-Wire Line Outputs: 3-pin male XLR-type

2-Wire (PL) Interface: 3-pin male and female XLR-type

External 24 Volt DC Input: coaxial power jack, 2.1 x 5.5 mm, locking bushing, compatible with Switchcraft® S760K plug

Power Requirements:

External: 24 volts DC nominal, acceptable range 20 to 28, maximum required current 750 milliamperes @ 20 volts. Universal mains input/24 volt DC power supply shipped with each unit.

2-Wire Party-Line (when serving as source): 24 to 32 volts DC, 175 milliamperes

Dimensions – Portable “Throw-Down” Version (Overall):

8.7 inches wide (22.1 cm)

1.72 inches high (4.4 cm)

8.3 inches deep (21.1 cm)

Mounting Options: single-unit (M45ARM-1), dual-unit (M45ARM-2), or “1/2-rack” (M45ARM-3) rack-mount front panels; single-unit and dual-unit panels use one space (1U) in a standard 19-inch rack, “1/2-rack” panel uses one space (1U) in a special 10.5-inch rack

Weight: 1.8 pounds (0.82 kg), rack-mount front panel adds 0.2 pounds (0.09 kg)

Specifications and information contained in this User Guide subject to change without notice.

Appendix A

Interfacing RTS® Matrix Intercom Systems with the Model 45A Interface

ADAM™ Matrix Intercom System Analog Ports to Model 45A Interface

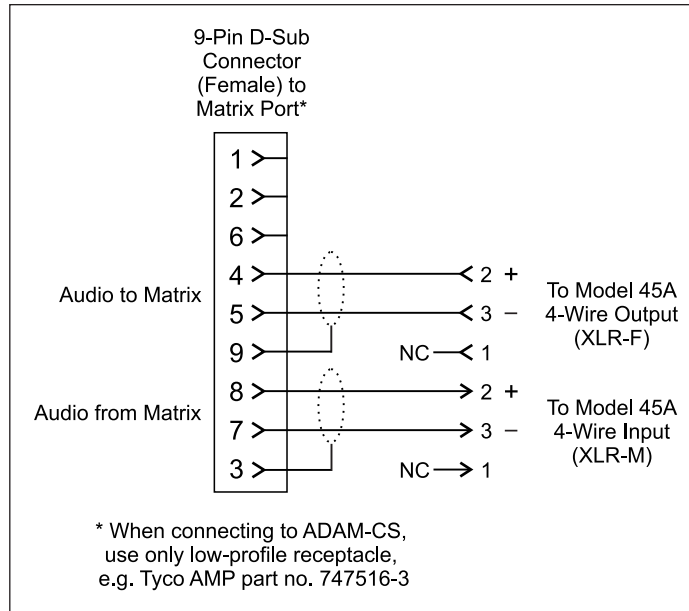

RVON-I/O I/O Connections to Model 45A Interface

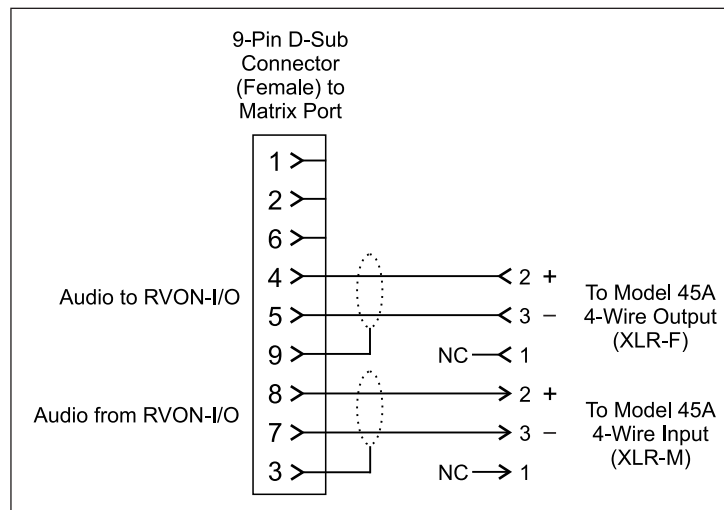

Appendix B

Interfacing Riedel® Artist™ Matrix Intercom System Analog Ports with the Model 45A Interface

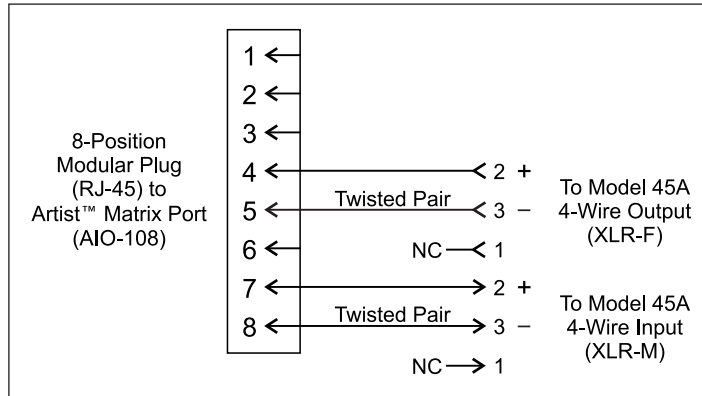

Back Panel Jack on Matrix Chassis

Pr 3
Pr 2 Pr 1 Pr 4
+ - + - + - + -
1 2 3 4 5 6 7 8

Jack Front View

T568B RJ-45 Wiring

Pin 1	WHT/ORG
Pin 2	ORG/WHT
Pin 3	WHT/GRN
Pin 4	BLU/WHT
Pin 5	WHT/BLU
Pin 6	GRN/WHT
Pin 7	WHT/BRN
Pin 8	BRN/WHT

8-Position Modular Plug (also known as RJ-45)

Pr 3
Pr 2 Pr 1 Pr 4
+ - + - + - + -
1 2 3 4 5 6 7 8

Plug Top View
(Release Tab on Bottom)

Appendix C

Interfacing Clear-Com® Matrix Intercom System Analog Ports with the Model 45A Interface

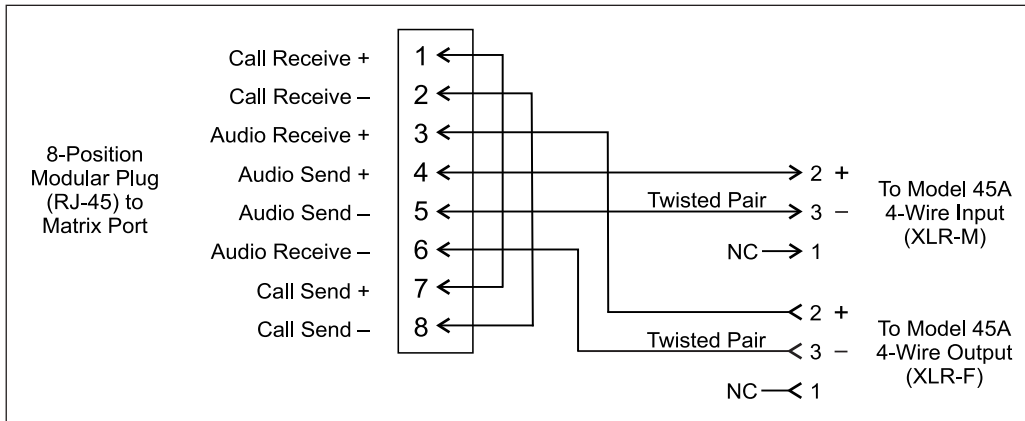

Appendix D

Model 45A Interface Front-Panel DIP Switch Configuration Chart

